

# STEEL DOOR & FRAMES

 Insulated Steel DOORSETS AND HOLLOW METAL DOORS & FRAMES were tested under HOKLAS accredited laboratories in compliance with

- ✓ **BS EN 1634 – 1 :2008** **qualified for -/120/120 Minutes**  
Fire resistance rating for doors, shutters and openable windows.
- ✓ **BS EN 1634 – 3 : 2004** **satisfied both of smoke leakage  $S_a$  &  $S_m$  requirement**  
Smoke control test for doors and shutter assemblies.
- ✓ **BS 476 : PART 22 : 1987** **qualified for -/240/- minutes of fire resistance rating**  
Method of the fire resistance of non-loadbearing of construction.
- ✓ **ASTM E90 – 09** **achieved STC 30 and 40 rating**  
Laboratory measurement of airborne sound transmission loss of building partitions.



# STEEL DOORS & FRAMES



- Fire, Smoke & Acoustic Performance
- Tested in HOKLAS Accredited Laboratory

# INTRODUCTION

Insulated Steel Doorset is steel facing within solid core of door leaf and cold rolled frame with thermal break test to BS EN 1634 – 1 : 2008, BS EN 1634 – 3 : 2004 & ASTM E90 – 09 that qualified for -/120/120 (minutes) of fire resistance rating, satisfied both of smoke leakage at ambient and medium (200oC) temperature and achieved 40 STC respectively.

Hollow Steel Doorset is steel sheet interlocking within honeycomb core of door leaf and cold rolled frame test to BS 476 : Part 22 : 1987 & ASTM E90 – 09 that qualified for -/240/- (minutes) of fire resistance rating and achieved 30 STC separately.

Our full line of TANDA Steel Doorsets is designed for fixing to masonry, incorporation with glazed panel and louvre & damper (for Hollow Metal Doorset only).





# FEATURE

## **Flexibility Demand:**

### **Door Leaf**

Single, Equal Double & Unequal Double

### **Door Frame**

Single & Double Rebate

### **Finishing**

G.M.S. with Primed, Synthetic or Powder Coating  
Stainless Steel in 304 or 316 with Mirror Polish,  
Hairline or Stain Finish

### **Incorporation**

Glazed Panel, Louvre & Damper

### **Ironmongery**

A Comprehensive Range of Surface Mounted  
Hardware

# TEST

Insulated Steel Doorsets were tested under HOKLAS accredited laboratories in compliance with BS EN 1634 – 1 :2008, fire resistance test for doors, shutters and openable windows, BS EN 1634 – 3 : 2004, smoke control test for doors and shutter assemblies and ASTM E90 – 09, laboratory measurement of airborne sound transmission loss of building partitions.

Hollow Steel Doorsets were tested under HOKLAS accredited laboratories in compliance with BS 476 : Part 22 : 1987 to determine of the fire resistance of non-loadbearing of construction and ASTM E90 – 09, laboratory measurement of airborne sound transmission loss of building partitions.



# HSD-DOOR FRAME CONSTRUCTION

➤ **Material Options**

Galvanized Mild Steel  
304, 316 Stainless Steel

➤ **Thickness**

1.5mm

➤ **Profile**

Single Rebate  
Double Rebate

➤ **Size of Depth**

80mm to 300mm for Single Rebate  
120mm to 300mm for Double Rebate

➤ **Size of Face**

25mm to 70mm

➤ **Size of Stop**

Minimum 15mm

➤ **Fixing**

Knock-down Corners  
Mechanically Fastened Corners

➤ **Hinge Reinforcement**

3.0mm

➤ **Strike Reinforcement**

2.0mm

➤ **G.M.S. Finish**

Primed  
Synthetic Paint  
Powder Coat

➤ **Stainless Steel Finish**

Hairline  
Mirror Polish  
Stain

## Door Frame Profile

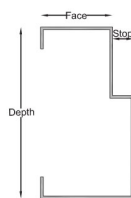

Single Rebate

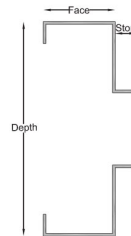

Double Rebate

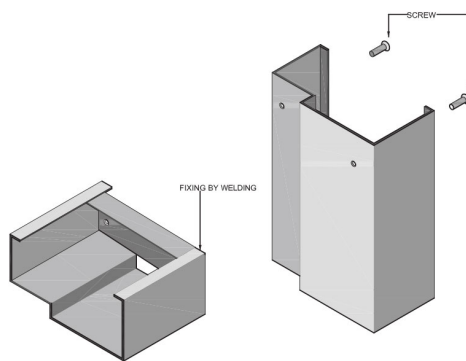

MECHANICALLY FASTENED CORNER

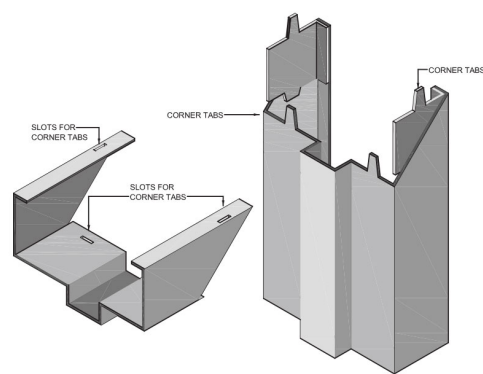

KNOCK-DOWN CORNER

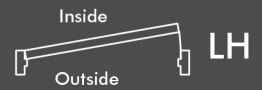
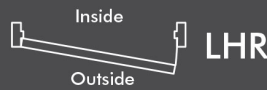
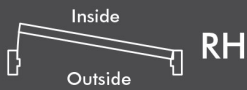
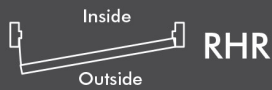
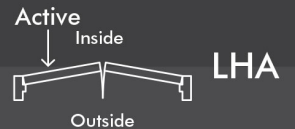
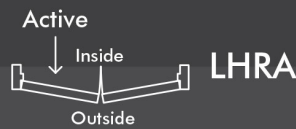
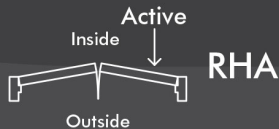
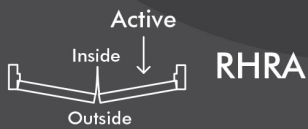
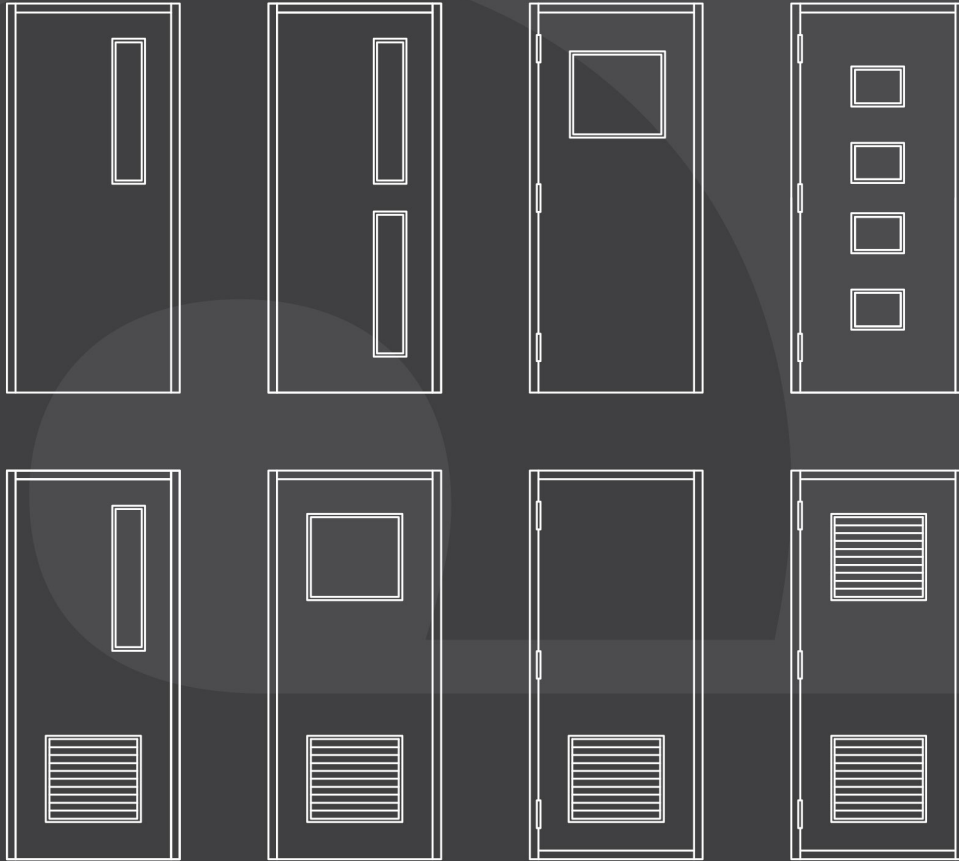

**Tanda International Co., Ltd.**

Tel : (852) 2156 9796

Fax : (852) 2156 9798

E-mail : sales@tanda.info

Website : www.tanda.info

Approval Distributor:



# HSD-DOOR LEAF CONSTRUCTION

- **Material Options**  
Galvanized Mild Steel  
304, 316 Stainless Steel
- **Door Thickness**  
45mm
- **Face Skins**  
1mm
- **Core**  
43mm Honeycomb Core
- **Fixing**  
Interlock
- **Top & Bottom Channels**  
1.5mm
- **Hinge Reinforcement**  
3.0mm
- **Lock Reinforcement**  
2.0mm
- **Closer Reinforcement**  
1.5mm
- **G.M.S. Finish**  
Primed  
Synthetic Paint  
Powder Coat
- **Stainless Steel Finish**  
Hairline  
Mirror Polish  
Stain

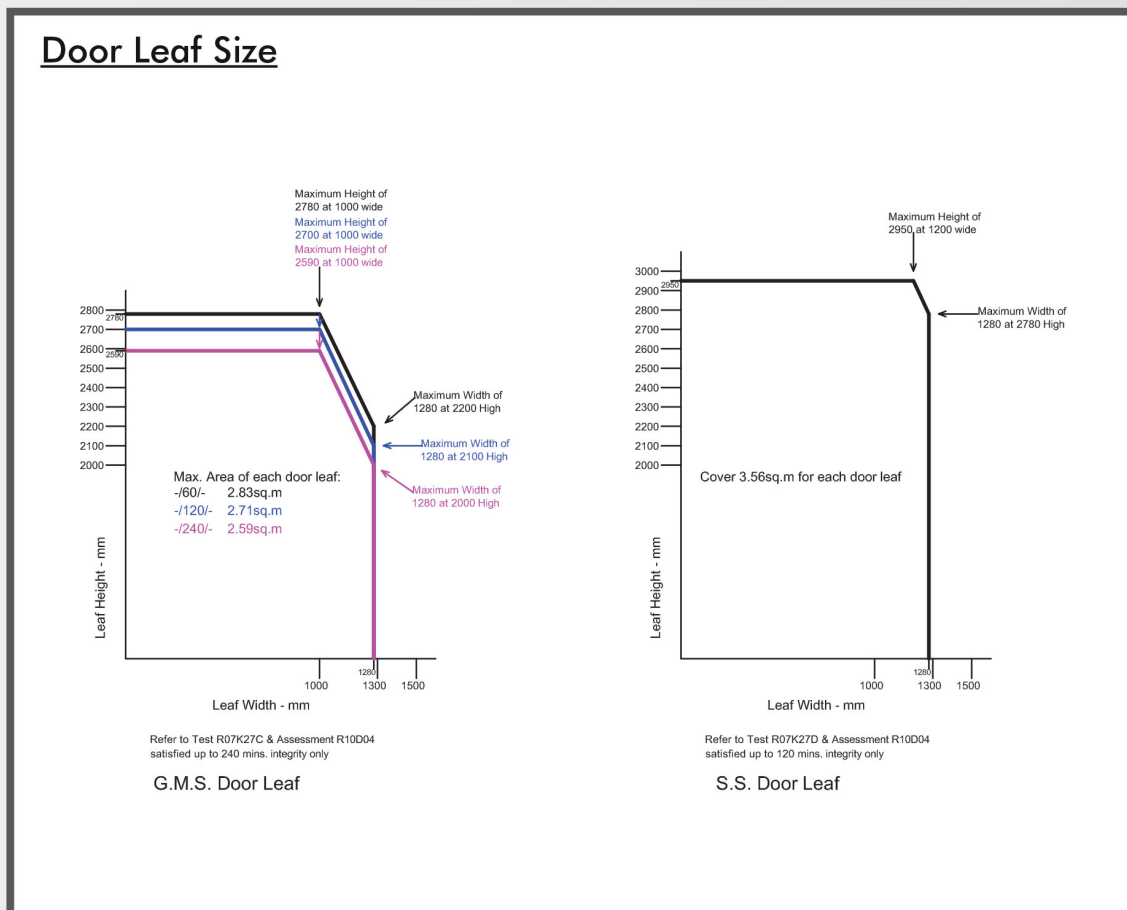

# ISD-DOOR FRAME CONSTRUCTION

➤ **Material Options**

Galvanized Mild Steel  
304, 316 Stainless Steel

➤ **Thickness**

1.5mm

➤ **Profile**

Single Rebate  
Double Rebate

➤ **Size of Depth**

118mm to 143mm for Single Rebate  
191mm to 226 for Double Rebate

➤ **Size of Face**

25mm to 38mm

➤ **Size of Stop**

25mm

➤ **Hinge Reinforcement**

3mm

➤ **Smoke Accessory**

Curved Fin Batwing Seal

➤ **G.M.S. Finish**

Primed  
Synthetic Paint  
Powder Coat

➤ **Stainless Steel Finish**

Hairline  
Mirror Polish  
Stain

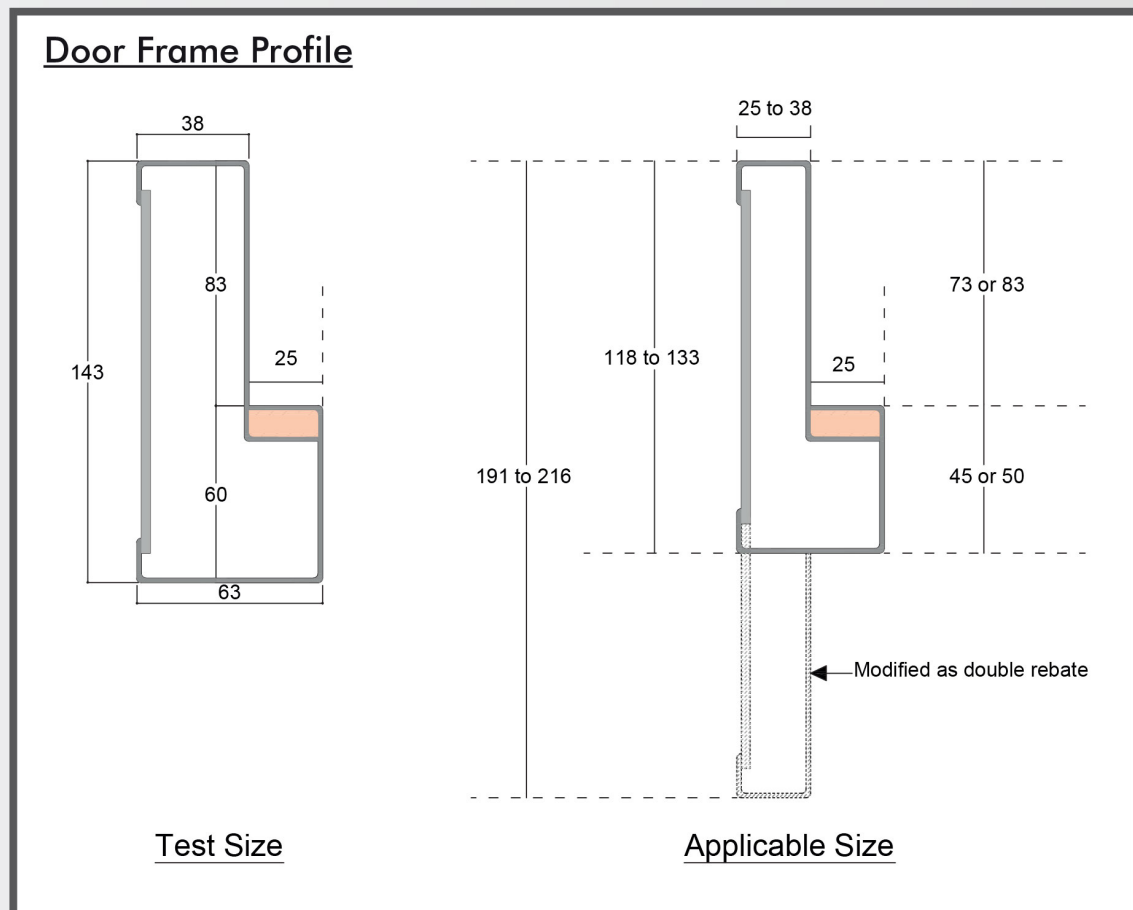



# ISD-DOOR LEAF CONSTRUCTION

➤ **Material Options**

Galvanized Mild Steel  
304, 316 Stainless Steel

➤ **Door Thickness**

70mm or 80mm

➤ **Face Skins**

1.2mm

➤ **Core**

50mm or 60mm TANDA Millboard

➤ **Hinge Reinforcement**

3mm

➤ **Closer Reinforcement**

1.5mm

➤ **Fire & Smoke Accessories**

DS & Finesse Seal  
Bottom Drop Seal  
Curved Fin Batwing Seal (For Double Leaves Only)

➤ **G.M.S. Finish**

Primed  
Synthetic Paint  
Powder Coat

➤ **Stainless Steel Finish**

Hairline  
Mirror Polish  
Stain

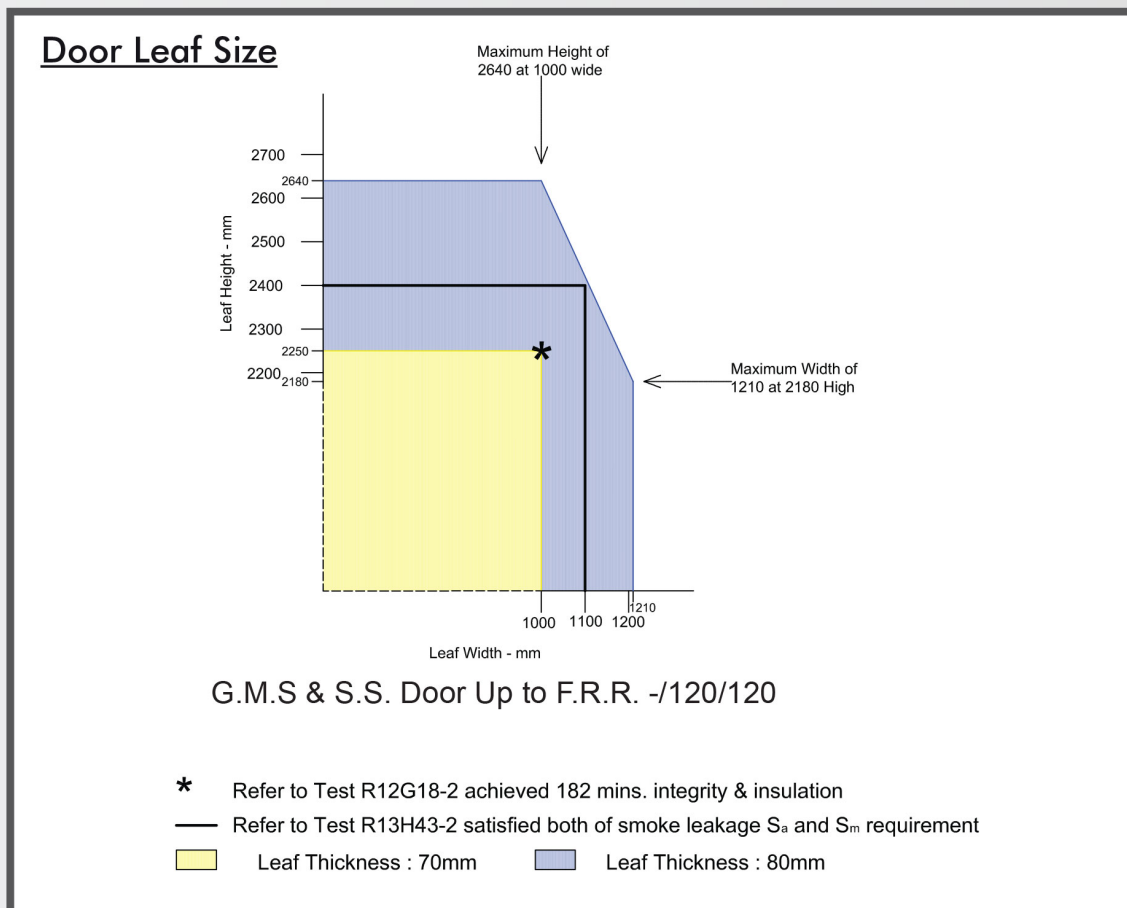



## Proposed Development At K.I.L. 11124 Sheung Shing Street,

Main Constructor :  
Paul Y. Construction Company Limited

Consultant Firm :  
LWK & Partners (HK) Limited / Cheung Kong  
(Holdings) Limited

No of Fire Protection Doors :  
104

Construction period :  
2008

## New Product Customization & Consolidation Centre, 12 Dai Kwai Centre, Tai Po Industrial Estate

Main Constructor :  
Hsin Chong Construction Group Limited

Consultant Firm :  
DPWT Design Limited / Kerry Properties Limited

No of Fire Protection Doors :  
188

Construction period :  
2010



## Redevelopment of Lam Tin Estate, Phase 3, 7 & 8

Main Constructor :  
Shui On Building Contractors Limited

Consultant Firm :  
Housing Department

No of Fire Protection Doors :  
101

Construction period :  
2009



## Redevelopment of Lower Ngau Tau Kok Estate Phase 1

Main Constructor :  
Yau Lee Holdings Limited

Consultant Firm :  
Hong Kong Housing Authority and Housing Department

No of Fire Protection Doors :  
51

Construction period :  
2012





## Landmark East - How Ming Street, Kwun Tong

Main Constructor :  
Paul Y. Construction Company Limited

Consultant Firm :  
Arthur C. S. Kwok Architects & Associates Limited /  
Cheung Kong (Holdings) Limited

No of Fire Protection Doors :  
137

Construction period :  
2010

## Skycity Marriott Hotel - P711 at Hong Kong International Airport

Main Constructor :  
Dragages Hong Kong Ltd

Consultant Firm :  
Aedas Ltd.

No of Fire Protection Doors :  
360

Construction period :  
2010





## Construction of Eastern Harbour Crossing Site, Phase 5&6, Yau Tong, Kowloon, Yau Lai Estate

Main Constructor :  
Shui On Construction Co., Ltd.

Consultant Firm :  
Hong Kong Housing Authority

No of Fire Protection Doors :  
403

Construction period :  
2011





## Steel Doorset

### Job Reference

| Project  | Main Contractor    | Architect / Client                | Year |
|--|--------------------|-----------------------------------|------|
| China Merchants Securities (HK) Co Ltd<br>27/F World Wide House<br>19 Des Voeux Road Central<br>Hong Kong  | I.T.E.M.           | China Merchants Securities        | 2008 |
| Lift Modernization At Ching Wai House,<br>Ching Yung House & Ching Kwai House<br>In Cheung Tsing Estate  | Shui On            | Housing                           | 2008 |
| SkyCity Marriott Hotel - P711<br>At Hong Kong International<br>Airport   | Dragages Hong Kong | Aedas Ltd. /<br>AAHK              | 2008 |
| Redevelopment of Quarantine B<br>Stable at Sha Tin<br>[ 2008 Olympics Equestrian Venues ]  | China State        | Ronald Lu /<br>HKJC               | 2008 |
| Proposed Development<br>At K.I.L. 11124 Sheung Shing Street,<br>Homantin, Kowloon  | Paul Y             | L.W.K. /<br>Cheung Kong           | 2008 |
| Proposed Office Development<br>On K.T.I.L. No. 242 at 102<br>How Ming Street, Kwun Tong,<br>Kowloon  | Paul Y             | Arthur C.S. Kwok /<br>Cheung Kong | 2008 |
| The Dairy Farm Co Ltd<br>Serve Room at 7/F, East<br>Block A , ATL Logistics Centre,<br>Berth 3, Kwai Chung   | I.T.E.M.           | Dairy Farm                        | 2008 |
| Sa Sa Cosmetic Co Ltd<br>Serve Room at 907 -909, Block B,<br>Ming Pao Industrial Centre,<br>18 Ka Yip Street, Chaiwan, HK  | I.T.E.M.           | Sa Sa Cosmetic                    | 2008 |
| Contract No. AL S304<br>Improvement Works to Hong Kong<br>Squash Centre, Western Park Centre,<br>Siu Sai Wan Sports Ground and<br>Stanley Main Beach Water Sports Centre | Kim Hung           | Design 2 /<br>ASD                 | 2008 |
| Wing Hang Bank Ltd<br>Serve Room at 13/F,<br>Ever Gain Centre,<br>43 – 57 Wang Wo Tsai Street,<br>Tsuen Wan, NT  | I.T.E.M.           | L.W.K. /<br>Wing Hang Bank        | 2008 |
| 14/F, Mita Centre,<br>552 Kwok Shui Road,<br>Kwai Chung, NT  | I.T.E.M.           | HK Boradband<br>Network           | 2008 |



## Steel Doorset

|   |                           |                                |      |
|---|---------------------------|--------------------------------|------|
| Housing Maintenance Works<br>At Po Kim House, Po Lam Estate,<br>Tseung Kwan O                   | Shun Yip                  | Housing                        | 2008 |
| Proposed Residential Redevelopment<br>At No. 1 & 1E La Salle Road, Kowloon.                     | Hanison – Hip Hing JV     | Integrated Design              | 2008 |
| No. 1 King Fung Path, Tuen Mun  | Chun Wo                   | Chow S Architect Ltd           | 2008 |
| Flat A, 3/F, Man Man Mansion,<br>No. 45 Jardine's Bazaar,<br>Causeway Bay, Hong Kong            | Luen Fung                 |                                | 2008 |
| 澳門果亞街龍城 3 樓   | I.T.E.M.                  | Owner                          | 2009 |
| 澳門南灣大馬路中華廣場 4 樓   | I.T.E.M.                  | Owner                          | 2009 |
| Ocean Park Redevelopment<br>Contract No. CW02 – Astounding Asia                                 | W. Hing                   | Maunsell /<br>Ocean Park       | 2009 |
| Proposed Alteration and Addition Works<br>At No. 8 Wing Hing Street, North Point,<br>Hong Kong. | Paul Y                    | Eddie Chan /<br>Cheung Kong    | 2009 |
| Residential Development at<br>Lot No. TWTL 367, Yau Kom Tau,<br>Tsuen Wan, N.T.                 | Paul Y                    | Aedas Ltd. /<br>Cheung Kong    | 2009 |
| 17/F, Pacific Place 3,<br>Queen's Road East, Hong Kong  | I.T.E.M.                  | ICBC                           | 2009 |
| 5/F 6 Science Park East Avenue,<br>Hong Kong Science Park, Shatin                               | I.T.E.M.                  | SAE Magnetics                  | 2009 |
| 4/F, Eastern Harbour Centre,<br>28 Hoi Chak Street, Hong Kong                                   | I.T.E.M.                  | Wing Lung Bank                 | 2009 |
| CLP Doorset for B2 to 2/F, 23/F<br>A & A Works at Kwun Tong<br>Wai Yip Street 223-231           | E Man                     | CLP /<br>Henderson             | 2009 |
| Relocation of I.T. Server Room,<br>11/F Avenida da Amizade, Macau                               | I.T.E.M.                  | Star World Hotel               | 2009 |
| A & A Works at No. 8 Wang Fu Street,<br>Yuen Long Industrial Estate, Yuen Long                  | Kinsway                   | Bright Future                  | 2009 |
| Redevelopment of Lam Tin Estate<br>Phase 3, 7 & 8   | Shui On                   | Housing                        | 2009 |
| AAHK Contract No. P322<br>SpyPier Building Works  | Gammon                    | Som Aedas JV /<br>AAHK         | 2009 |
| CLP Doorset for KIL 11167 & KIL11168<br>West Kowloon  | Hong Kong<br>Construction | CLP / MLA /<br>Nan Fung / Sino | 2009 |





## Steel Doorset

|  |                        |                       |      |
|--|------------------------|-----------------------|------|
| CLP Doorset for Ecopark EP07-03 Biodiesel Manufacturing Plant  | Chamway                | CLP / Chamway         | 2009 |
| Castle Peak 'B' Power Station Emission Control Project   | WuHan KaiDi            | CLP                   | 2010 |
| Contract No. EX T 308<br>Proposed Extension Project to Jockey Club Elaine Field School<br>GLA-TP417 Fu Chung Lane, Tai Po, N.T.            | Kim Hung               | Thomas Chow / ASD     | 2010 |
| Contract No. SS T309<br>The Construction of a Primary School At Redevelopment of Shek Kip Mei Estate Phase 4, Sham Shui Po                 | China Harbour          | MLA / CLP / ASD       | 2010 |
| Product Customization & Consolidation Centre, 12 Dai Kwai Centre, Tai Po Industrial Estate   | Hsin Chong             | DPWT / Kerry          | 2010 |
| 東涌國泰城天臺機房  | Shung Chai             | Cathay Pacific        | 2010 |
| Contract P510 – AAHK<br>Central Concourse Gabin G<br>Related Works of T1   | Union                  | AAHK                  | 2010 |
| MW086 Ventilation Enhancement Works For Smoking Lounges in Central Concourse of T1   | Union                  | AAHK                  | 2010 |
| Fire Improvement Works<br>At G/F – 2/F, Seapower Industrial Centre, 177 Hoi Bun Road, Kwun Tong, Kowloon                                   | OLE                    | Samson Paper          | 2010 |
| External Façade, A & A Works, Interior Fitting-out and E&M Services at Proposed EK Tower, No. 2-10, Lyndhurst Terrace, Central, Hong Kong. | Shun Lee               | K C Wong & Associated | 2010 |
| Fitting Out Works for Sik Sik Yuen Of Wong Tai Sin Temple Abbot Hall   | Paul Y                 |                       | 2010 |
| MTR West Island Line Contract 704  | Gammon / Nishimatsu JV | Atkins Arup JV        | 2010 |
| LZ 3652, Tai Nam Street, Kln., Hong Kong   | Far East               |                       | 2010 |
| Contract No. SS T303<br>The Construction of a Primary School At Wylie Road, Kowloon  | China Harbour          | Chows Arch / ASD      | 2010 |
| Proposed Conversion of Existing Verandah to Plat Room at Wai Yee Block Carits Medical Centre 111 Wing Hong Street Kowloon N.K.I.L. 4715    | Kinsway                |                       | 2010 |





## Steel Doorset

|   |                       |   |        |
|---|-----------------------|---|--------|
| Eastern Harbour Crossing Site Phase 5 & 6   | Shui On               | Housing   | 2011   |
| Data Centre at 28/F, Octa Tower,  | I.T.E.M.              | Li Fung Trinity                                   | 2011   |
| Date Centre at 37/F, Citibank Tower, 3 Garden Road, Central, Hong Kong  | I.T.E.M.              | ICBCI   | 2011   |
| Fire Improvement Works At 1/F – 2/F, Seapower Industrial Centre, 177 Hoi Bun Road, Kwun Tong, Kowloon                   | OLE                   | Samson Paper                                      | 2011   |
| AAHK Contract P505 – West Hall Airline Lounge Expansion Works of T1   | Union                 | AAHK  | 2011   |
| AAHK Contract P504 – North-West Concourse Airline Lounge Expansion Works of T1  | Pat Davie             | AAHK  | 2011   |
| District Term Contract: Wong Tai Sin, Tsing Yi, Tsuen Wan and Islands (1) 2011/2014 Contract No.: 20100099              | Shui On               | Housing   | 2012   |
| Redevelopment of Lower Ngau Tau Kok Estate Phase 1  | Yau Lee               | Housing   | 2012   |
| Proposed Factory Re-development At 46 Wang Lee Street, Yuen Long Ind. Estate  | Wah Fai               | Roger Sze   | 2012   |
| Tuen Mun Area 18  | Shui On               | Housing   | 2012   |
| New Data Centre Development At Tseung Kwan O TKOTL  | Hsin Chong – Maeda JV | Wong & Ouyang                                     | 2013   |
| Back of House Refurbishment For Mandarin Oriental Hong Kong   | Easy Smart            | Mandarin Oriental HK                              | 2013   |
| Server Rooms in Hung To Road Office, Watch Tower Bible and Tract Society Of Pennsylvania                                | Easy Smart            | Watch Tower Bible & Tract Society of Pennsylvania | 2013   |
| The Innovation Tower for The Hong Kong Polytechnic University, Hung Hom, HK   | Shui On               | AGC   | 2013   |
| AAHK Contract P522 – East Hall Icon Shops   | Maeda                 | AAHK  | 2013   |
| Research & Academic Building The Hong Kong University of Science & Technology, Clear Water Bay, Sai Kung, DD227 Lot 846 | Hsin Chong            | Ronald Lu   | W.I.P. |
| Proposed Office Building on I.L. 2273 Sec. C.C. at No. 93 & 95 King's Road, Hong Kong                                   | New House             | A.Lead Architects                                 | W.I.P. |



## **Steel Doorset**

Proposed Bus Servicing & Supporting Site  
For KMB at Fuk Wang St., Yuen Long, N.T.

Ming Hing Tai

ADO HK

W.I.P.

MTRCL Contract K1155-12C  
Provision of New Bus Maintenance Centre  
At Tai Po

Maeda

Meinhardt /  
Kwong & Associates

W.I.P.

Ocean Park – Renovation Works of  
Shark Mystique

Seemly

LD Asia

W.I.P.